



128-Kbit I²C-compatible Serial EEPROM

DATASHEET

Features

- Supply Voltage: 1.7V to 5.5V
- 2-wire Serial Interface I²C Compatible
 - 400 kHz and High Speed 1MHz Transfer Rate Compatibility
- Byte and Page (up to 64 Bytes) Write Mode
 - Partial Page Write Allowed
- Self-timed Write Cycle (5ms Maximum)
- Hardware Write Protection on the Whole Memory Array
- Additional 64-byte Write Lockable Page and 128-bit Unique ID
- Schmitt Trigger, Filtered Inputs for Noise Suppression
- High Reliability
 - Endurance: 2,000,000 Write Cycles
 - Data Retention: 200 Years
 - ESD Protection (Human Body Model): 4000V+
(Charged Device Model): 1000V+
- Low Operating Current
 - Write Current: 1mA (Maximum)
 - Read Current: 0.5mA (Maximum)
 - Standby Current: 1μA (Maximum)
- Operating Temperature Range: -40°C to +105°C
- Green Packaging Options (Pb/Halide-free/RoHS Compliant)
 - TSSOP-8, SOP-8, SOT23-5, UDFN-8
- Moisture Sensitivity Level:3

Description

The WB24C128 is a 128-Kbit I²C-compatible Serial EEPROM (Electrically Erasable Programmable Memory) device. The device is designed to operate in a supply voltage range of 1.7V to 5.5V, with a maximum of 1MHz transfer rate. The operating temperature range is from -40°C to +105°C. The device incorporates a Write Protection pin used for hardware Write Protection on the whole memory array.

The Serial EEPROM memory is organized as 256 pages of 64 bytes each, totaling 16384*8 bits. The WB24C128 offers an additional 64-byte Identification Page for users to store sensitive application parameters. This page can be permanently locked in Read-only mode after the application data is written into the Identification Page. The WB24C128 also offers a separate memory block containing a factory programmed 128-bit Unique ID. This block is in Read-only mode and can be accessed to by sending a specific Read command.

The WB24C128 is delivered in Lead-free green packages: TSSOP-8, SOP-8, SOT23-5 and UDFN-8.

Table of Contents

Features	1
Description	1
1 Pin Descriptions and Pin Configuration	3
2 Functional Block Diagram	4
3 Device Communication	5
3.1 Start Condition	5
3.2 Stop Condition.....	5
3.3 Acknowledge (ACK).....	6
3.4 Standby Mode	6
3.5 Software Reset.....	6
3.6 Device Reset and Initialization	6
3.7 Data Security.....	7
4 Device Addressing	8
5 Read and Write Operations.....	9
5.1 Write Operations	9
5.1.1 Byte Write	9
5.1.2 Page Write	9
5.1.3 Write Cycle Timing.....	11
5.1.4 Acknowledge (ACK) Polling.....	12
5.1.5 Write Identification Page.....	12
5.1.6 Lock Identification Page.....	13
5.2 Read Operations	14
5.2.1 Current Address Read	14
5.2.2 Random Read.....	14
5.2.3 Sequential Read	15
5.2.4 Read Identification Page.....	16
5.2.5 Read Lock Status	16
5.2.6 Read Unique ID	16
6 Electrical Specifications	18
6.1 Absolute Maximum Ratings.....	18
6.2 DC Characteristics	18
6.3 AC Characteristics	18
6.4 Pin Capacitance	20
6.5 Reliability Characteristics	20
7 Initial Delivery State	21
8 Ordering Information.....	22
9 Package Information	23
9.1 TSSOP Package Information	23
9.2 SOP Package Information.....	24
9.3 SOT23-5 Package Information.....	25
9.4 UDFN Package Information	26
10 Park Marking Scheme.....	27
11 Revision History	28

1 Pin Descriptions and Pin Configuration

Table 1–1 Pin Descriptions

Symbol	Type	Name and Function
E0 E1 E2	Input	Device Address Inputs: The E0, E1, and E2 pins are device address inputs for compatibility with other 2-wire Serial EEPROM devices. These pins can be directly connected to V _{CC} or GND in any combination, allowing up to eight devices on a single bus system. If these pins are left floating, the E0, E1, and E2 pins will be internally pulled down to GND.
SDA	Input/Output	Serial Data: The SDA pin is an open-drain bidirectional input/output pin used to serially transfer data to and from the device.
SCL	Input	Serial Clock: The SCL pin is used to provide a clock to the device and is used to control the flow of data to and from the device. Command and input data present on the SDA pin is always latched in on the rising edge of SCL, while output data on the SDA pin is always clocked out on the falling edge of SCL.
V _{CC}	Power	Device Power Supply: The V _{CC} pin is used to supply the source voltage to the device. Operations at invalid V _{CC} voltages may produce spurious results and should not be attempted.
GND	Power	Ground: The ground reference for the power supply. GND should be connected to the system ground.
WP	Input	Write Protection: The WP pin is used to write protect the entire contents of the memory. When the WP pin is connected to Power Supply, the entire memory array becomes Write-protected, that is, the device becomes Read-only. When the WP pin is connected to GND, Write operations are enabled. If the pin is left floating, the WP pin will be internally pulled down to GND. When the WP pin is driven high, the device address byte and the word address bytes are acknowledged, data bytes are not acknowledged.

Figure 1–1 Pin Configuration

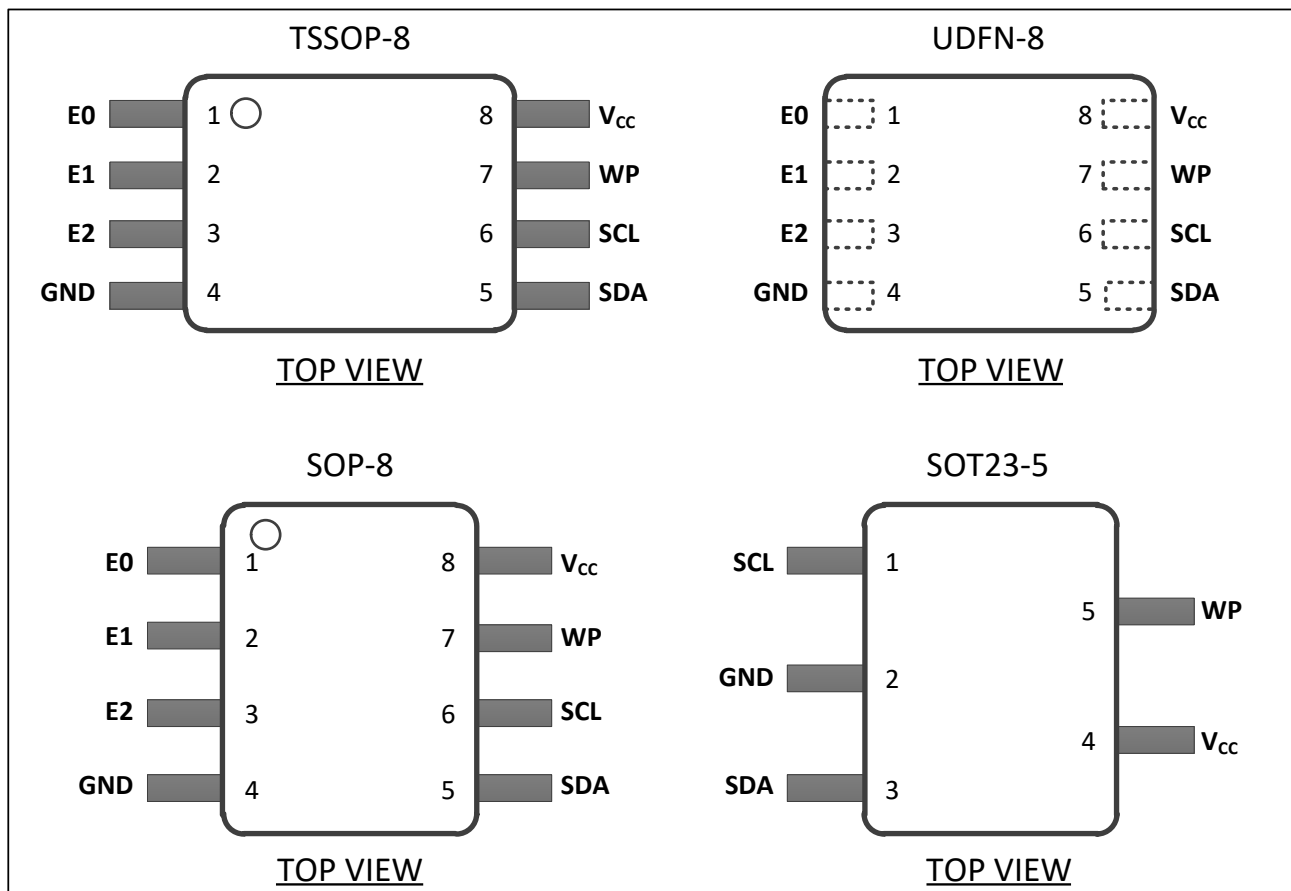

2 Functional Block Diagram

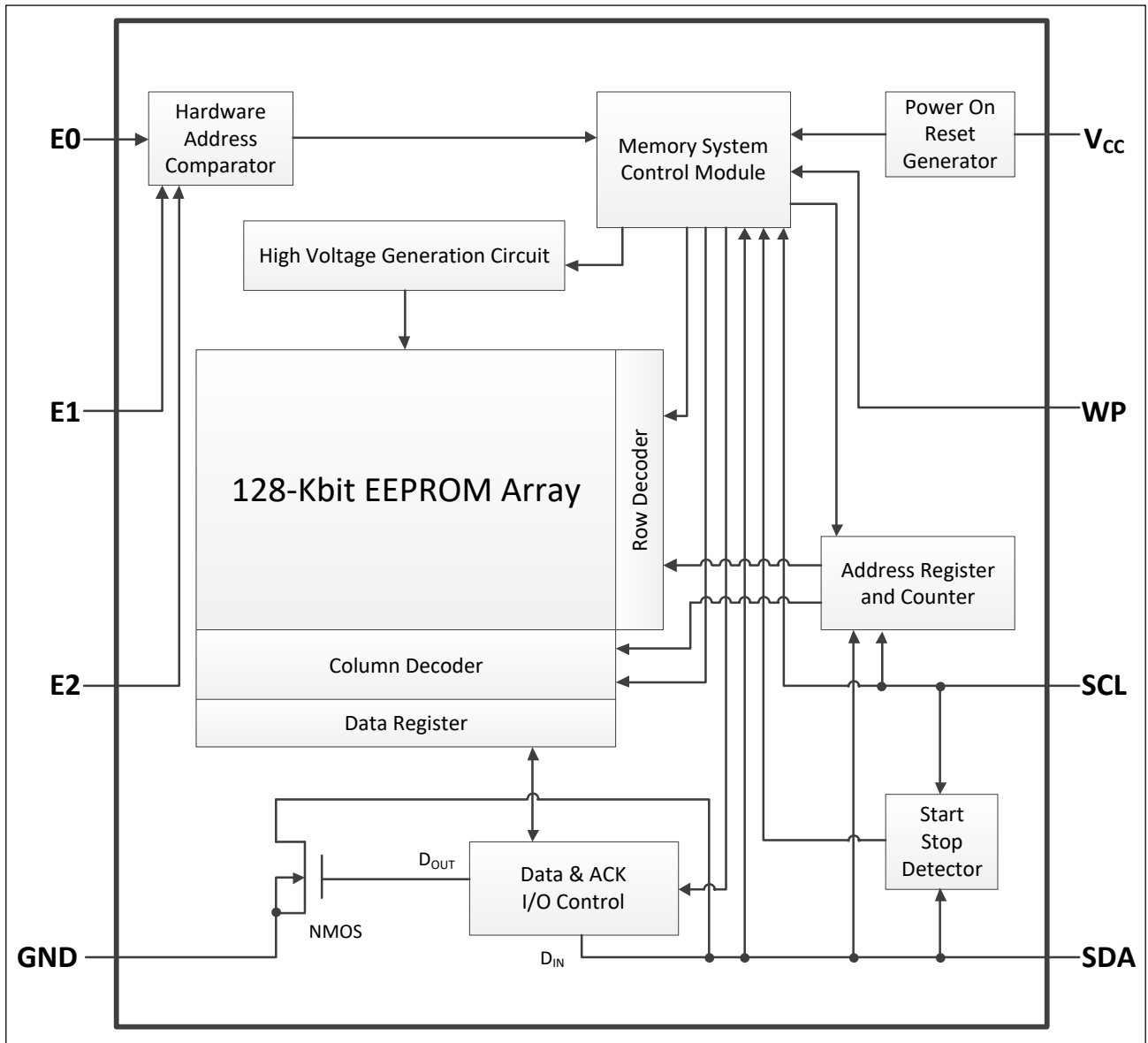

3 Device Communication

The WB24C128 operates as a slave device and utilizes a 2-wire serial interface to communicate with the Master. The Master initiates and controls all Read and Write operations to the slave devices on the serial bus, and both the Master and the slave devices can transmit and receive data on the bus.

The serial interface is comprised of just two signal lines: the Serial Clock (SCL) and the Serial Data (SDA). Data is always latched into the WB24C128 on the rising edge of SCL and is always output from the device on the falling edge of SCL. Both the SCL pin and SDA pin incorporate integrated spike suppression filters and Schmitt Triggers to minimize the effects of input spikes and bus noise.

All command and data information is transferred with the Most Significant Bit (MSB) first. During the bus communication, one data bit is transmitted every clock cycle, and after eight bits of data has been transferred, the receiving device must respond with an acknowledge or a no-acknowledge response bit during a ninth clock cycle generated by the Master. Therefore, nine clock cycles are required for every one byte of data transferred. There is no unused clock cycle during any Read or Write operation, so there must not be any interruptions or breaks during the data stream.

During data transfers, data on the SDA pin must only change while SCL is low, and the data must remain stable while SCL is high. If data on the SDA pin changes while SCL is high, then either a Start or a Stop condition will occur. The number of data bytes transferred between a Start and a Stop condition is not limited and is determined by the Master.

3.1 Start Condition

A Start condition occurs when there is a high-to-low transition on the SDA pin while the SCL pin is stable in Logic 1 state. The Start condition must precede any command as the Master uses a Start condition to initiate any data transfer sequence (see [Figure 3-1](#)). The WB24C128 will continuously monitor the SDA and SCL pins for a Start condition, and the device will not respond unless one is given.

Figure 3-1 Start, Stop, and ACK

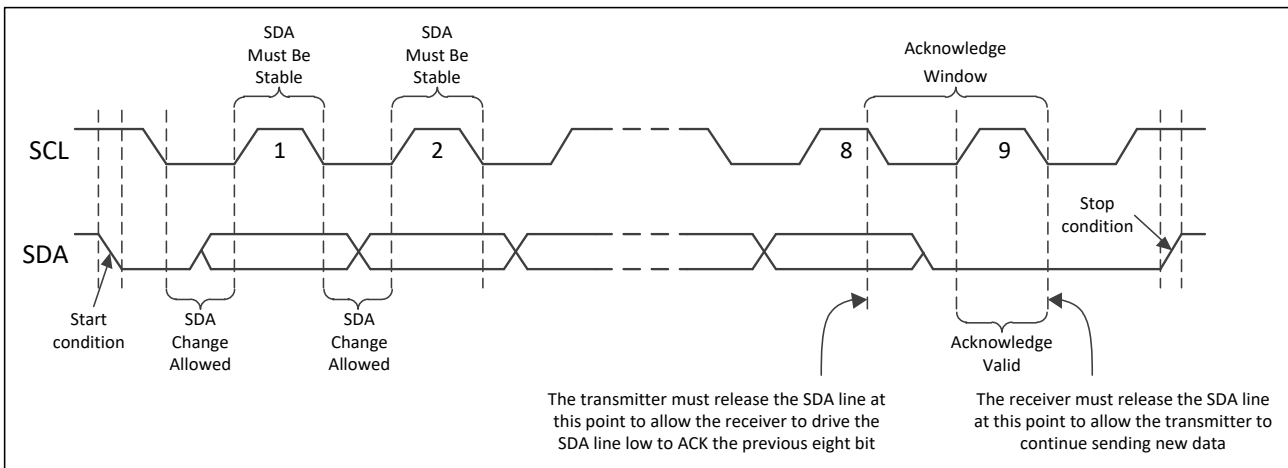

3.2 Stop Condition

A Stop condition occurs when there is a low-to-high transition on the SDA pin while the SCL pin is stable in Logic 1 state (see [Figure 3-1](#)). A stop condition terminates communication between the WB24C128 and the Master. A Stop condition at the end of a Write command triggers the EEPROM internal write cycle. Otherwise, the WB24C128 subsequently returns to Standby mode after receiving a Stop condition.

3.3 Acknowledge (ACK)

After each byte of data is received, the WB24C128 should acknowledge to the Master that it has received the data byte successfully. This is accomplished by the Master first releasing the SDA line and providing the ACK/NACK clock cycle (a ninth clock cycle for every byte). During the ACK/NACK clock cycle, the WB24C128 must output Logic 0 as ACK for the entire clock cycle so that the SDA line must be stable in Logic 0 state during the entire high period of the clock cycle (see [Figure 3-1](#)).

3.4 Standby Mode

The WB24C128 features a low-power Standby mode which is enabled:

- (1) Upon power-up;
- (2) After the receipt of a Stop condition in Read operation;
- (3) The completion of any internal operations.

3.5 Software Reset

After an interruption in protocol, power loss, or system reset, any 2-wire part can be reset by following these steps: (1) Create a Start condition; (2) Clock nine cycles; (3) Create another Start condition followed by a Stop condition (see [Figure 3-2](#)).

Figure 3-2 2-wire Software Reset

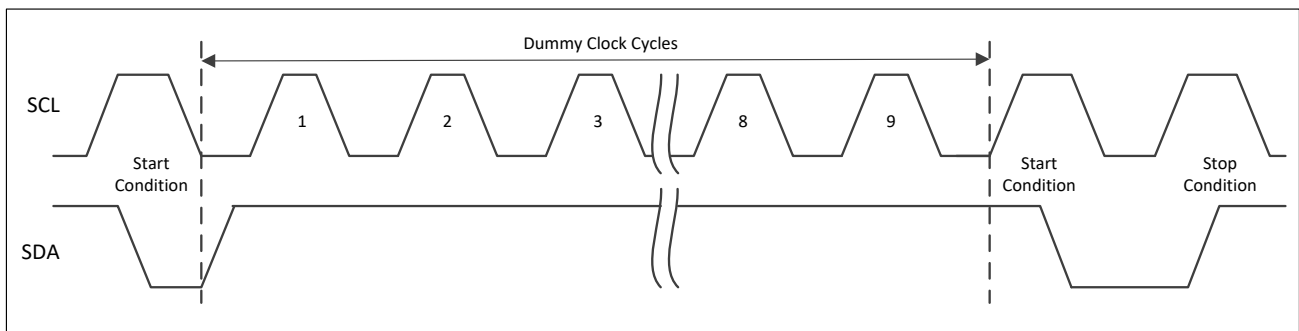

3.6 Device Reset and Initialization

The WB24C128 incorporates a Power-On Reset (POR) circuit to prevent inadvertent operations during power-up. On a cold power-up, the device does not respond to any instructions until the supply voltage reaches the internal power-on reset threshold voltage (V_{POR}). The supply voltage must rise continuously between V_{POR} and $V_{CC}(\text{Min})$ without any ring back to ensure a proper power-up. Once the supply voltage passes V_{POR} , the device is reset and enters Standby mode. However, no protocol should be issued to the device until a valid and stable supply voltage is applied for the time specified by the t_{INIT} parameter. The supply voltage must remain stable and valid until the end of the protocol transmission, and for a Write instruction, until the end of the internal write cycle (see [Figure 3-3](#)).

This POR behavior is bi-directional. It protects the WB24C128 against brown-out failure caused by a temporary loss of power. In a similar way, as soon as the supply voltage drops below the internal brown-out reset threshold voltage (V_{BOR}), the device is reset and stops responding to any instructions (see [Figure 3-3](#)). The V_{BOR} level is set below the V_{POR} level.

Parameters related to power-up and power-down conditions are listed in [Table 3-1](#).

Figure 3–3 Power-up and Power-down Timing

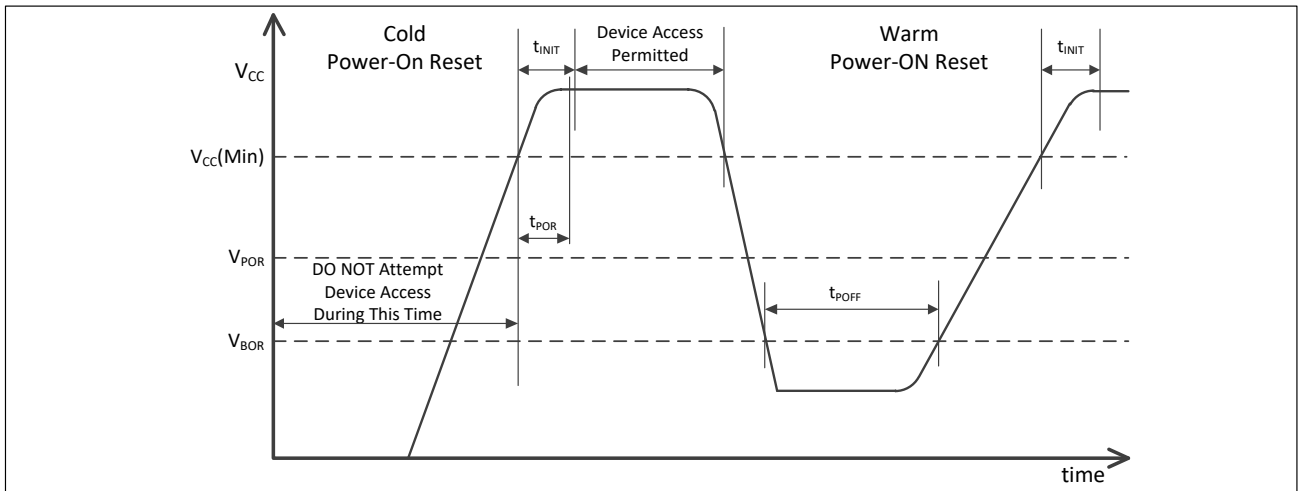

Table 3–1 Power-up and Power-down Conditions

Symbol	Parameter	Min	Max	Units
t_{POR}	Power-On Reset Time	-	10.0	ms
V_{POR}	Power-On Reset Voltage	-	1.6	V
V_{BOR}	Brown-out Reset Voltage	0.8	-	V
t_{INIT}	Time from Power-On to First Command	10.0	-	ms
t_{POFF}	Warm Power Cycle Off Time	1.0	-	ms

3.7 Data Security

The WB24C128 incorporates a hardware data protection feature that allows the user to write protect the whole memory array (and Identification Page) when the WP pin is connected directly to V_{CC} .

4 Device Addressing

The WB24C128 requires a 7-bit device address and a Read/Write select bit following a Start condition from the Master to initiate communication with the Serial EEPROM. The device address byte is comprised of a 4-bit device type identifier followed by three device address bits (E2, E1, and E0) and a $\overline{R/W}$ select bit and is clocked by the Master on the SDA pin with the most significant bit (bit 7) first.

The WB24C128 will respond to two unique device type identifiers. The device type identifier of '1010' is necessary to select the device memory for normal Read or Write operation. The device type identifier of '1011' is used to select the Identification Page for Read or Write/Lock operation. The device type identifier of '1011' is also used for Read Unique ID operation (see [Table 4-1](#)).

The software device address bits (E2, E1 and E0) must match their corresponding hard-wired device address inputs (E2, E1 and E0), allowing up to eight devices on the bus at the same time. The eighth bit of the address byte is the $\overline{R/W}$ operation selection bit. A Read operation is selected if this bit is Logic 1, and a Write operation is selected if this bit is Logic 0. Upon a compare of the device address byte, the WB24C128 outputs an ACK or a NACK during the ninth clock cycle if the compare is true or not true, respectively. The device will return to the low-power Standby mode after a NACK.

Once the WB24C128 has acknowledged the device address byte, the device waits for the Master to send two word address bytes (first word address byte sent first, followed by the second word address byte) for a certain Read or Write instruction according to [Table 4-2](#). The WB24C128 responds to each address byte with an ACK.

Table 4-1 WB24C128 Device Address Byte

Function	bit 7	bit 6	bit 5	bit 4	bit 3	bit 2	bit 1	bit 0
	Device Type Identifier				Device Address			Read/Write
When accessing the 128-Kbit memory array	1	0	1	0	E2	E1	E0	$\overline{R/W}$
When accessing the Identification Page	1	0	1	1	E2	E1	E0	$\overline{R/W}$
When accessing the Lock Identification Page bit	1	0	1	1	E2	E1	E0	0
When accessing the Unique ID	1	0	1	1	E2	E1	E0	1

Table 4-2 WB24C128 Word Address Bits

Function	First Word Address Byte								Second Word Address Byte							
	bit 15	bit 14	bit 13	bit 12	bit 11	bit 10	bit 9	bit 8	bit 7	bit 6	bit 5	bit 4	bit 3	bit 2	bit 1	bit 0
Random Read	X ^[1]	X	A13 ^[2]	A12	A11	A10	A9	A8	A7	A6	A5	A4	A3	A2	A1	A0
Byte/Page Write	X	X	A13	A12	A11	A10	A9	A8	A7	A6	A5	A4	A3	A2	A1	A0
Read Identification Page	X	X	X	X	X	0	0	X	X	X	A5	A4	A3	A2	A1	A0
Write Identification Page	X	X	X	X	X	0	0	X	X	X	A5	A4	A3	A2	A1	A0
Lock Identification Page	X	X	X	X	X	1	0	X	X	X	X	X	X	X	X	X
Read Lock Status	X	X	X	X	X	0	0	X	X	X	X	X	X	X	X	X
Read Unique ID	X	X	X	X	X	0	1	X	X	X	X	X	A3	A2	A1	A0

Notes: ^[1] X = Bit is Don't Care.

^[2] A = Significant Address Bit.

5 Read and Write Operations

5.1 Write Operations

5.1.1 Byte Write

For a Byte Write operation, the Master sends a Start condition followed by the device type identifier of '1010', the device address bits and the $\overline{R/W}$ select bit set to Logic 0. The WB24C128 responds with an ACK during the ninth clock cycle and waits for the Master to send two word address bytes (first word address byte and second word address byte). Then the device responds to each word address byte with an ACK. After receiving ACKs from the WB24C128, the Master transmits one data byte. If the addressed location has been Write-protected, by WP pin connected to V_{CC} , the device responds with a NACK, and the location is not modified. If the addressed location is not Write-protected, by WP pin set to GND, the device will respond with an ACK (see [Figure 5-1](#) and [Figure 5-2](#)). The Master ends the Byte Write sequence with a Stop condition during the 10th clock cycle to initiate the internally self-timed write cycle. A Stop condition issued during any other clock cycle during the Write operation will not trigger the internal write cycle.

Once the write cycle begins, the preloaded data word will be programmed in the amount of time not to exceed the t_{WR} specification (see [Figure 5-5](#)). During the time, the Master should wait a fixed time by the t_{WR} specification, or for time sensitive applications, an ACK polling routine can be implemented. All inputs are ignored by the device during the write cycle and the device will not respond until the write cycle is completed. The Serial EEPROM will increment its internal address counter each time a byte is written.

5.1.2 Page Write

The 128-Kbit Serial EEPROM is capable of writing up to 64 data bytes at a time by executing the Page Write protocol sequence. A partial or full Page Write operation is initiated the same as a Byte Write operation except that the Master does not send a Stop condition after the first data word is clocked in. Instead, after the device has acknowledged to the first data word, the Master can transmit up to sixty-three more data words. The device responds with an ACK after each data word is received if the WP pin is set to GND while the device is not acknowledged to each data word and the addressed locations are not modified if the WP pin is connected to V_{CC} (see [Figure 5-3](#) and [Figure 5-4](#)). After the device acknowledges to the last data word, the Master should terminate the Page Write sequence with a Stop condition to start the internal write cycle. A Stop condition issued at any other clock cycle will not initiate the internally self-timed write cycle and the Write sequence will have to be repeated again. Once the write cycle begins, the data words should be programmed in the amount of time not exceeding the t_{WR} specification (see [Figure 5-5](#)). During this time, the Master should wait a fixed time by the specified t_{WR} parameter, or for time sensitive applications, an ACK polling routine can be implemented.

The lower six bits of the word address are internally incremented following the receipt of each data word. The higher word address bits are not incremented, retaining the memory page row location. When the internally generated word address reaches the page boundary, then the following data word is placed at the beginning of the same page. If more than sixty-four data words are transmitted to the device, the data word address will roll over and the previous data will be overwritten. The address roll-over during a Write sequence is from the last byte of the current page to the first byte of the same page.

Figure 5–1 Byte Write Operation with Write Protection Pin Set to Low

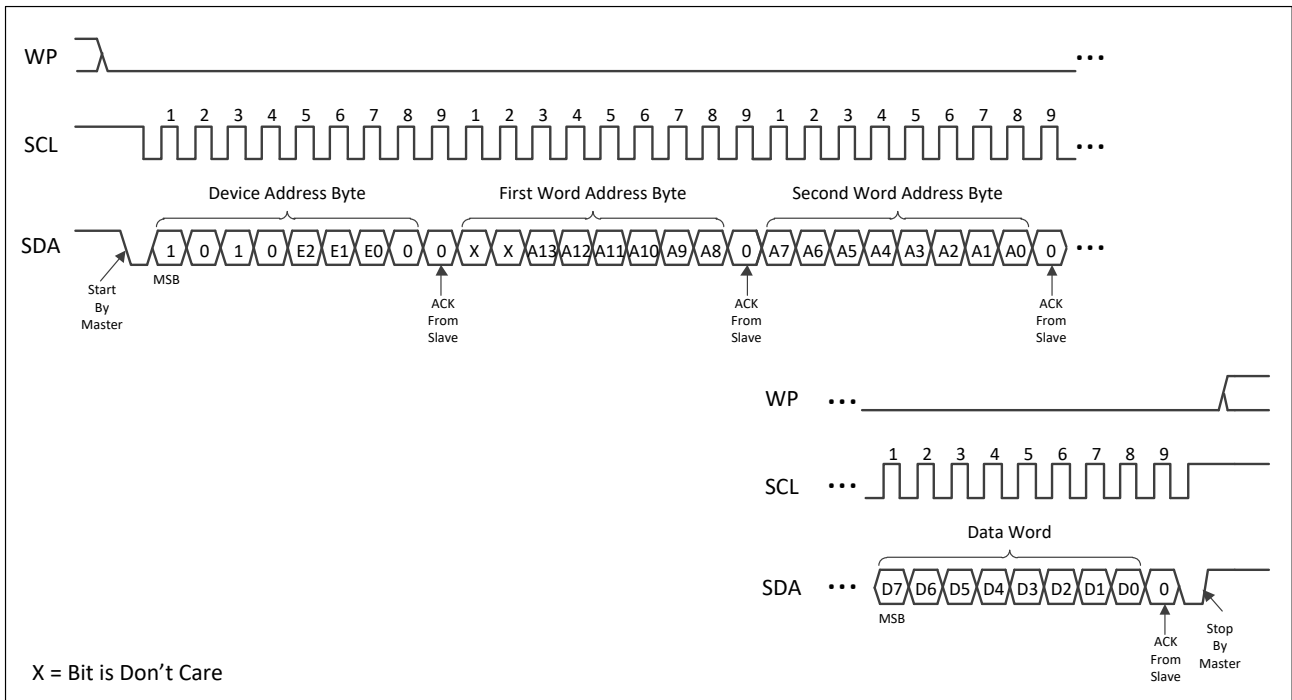

Figure 5–2 Byte Write Operation with Write Protection Pin Set to High

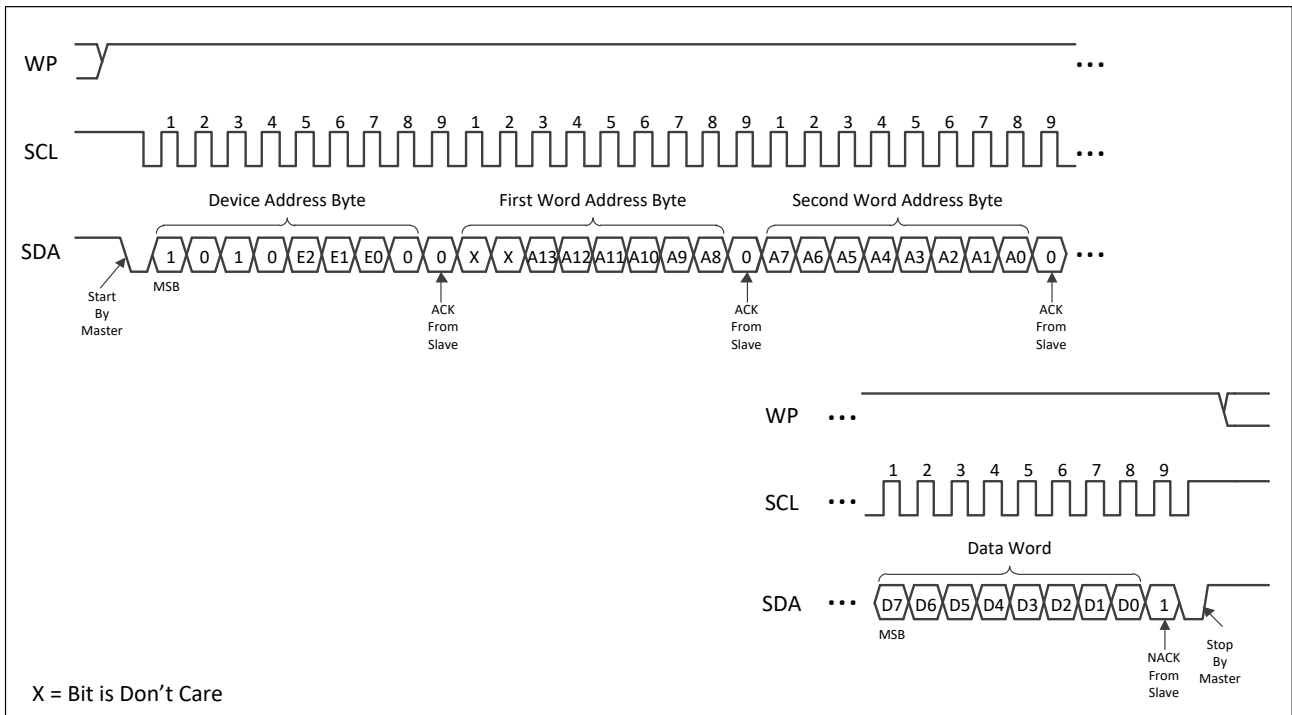

Figure 5–3 Page Write Operation with Write Protection Pin Set to Low

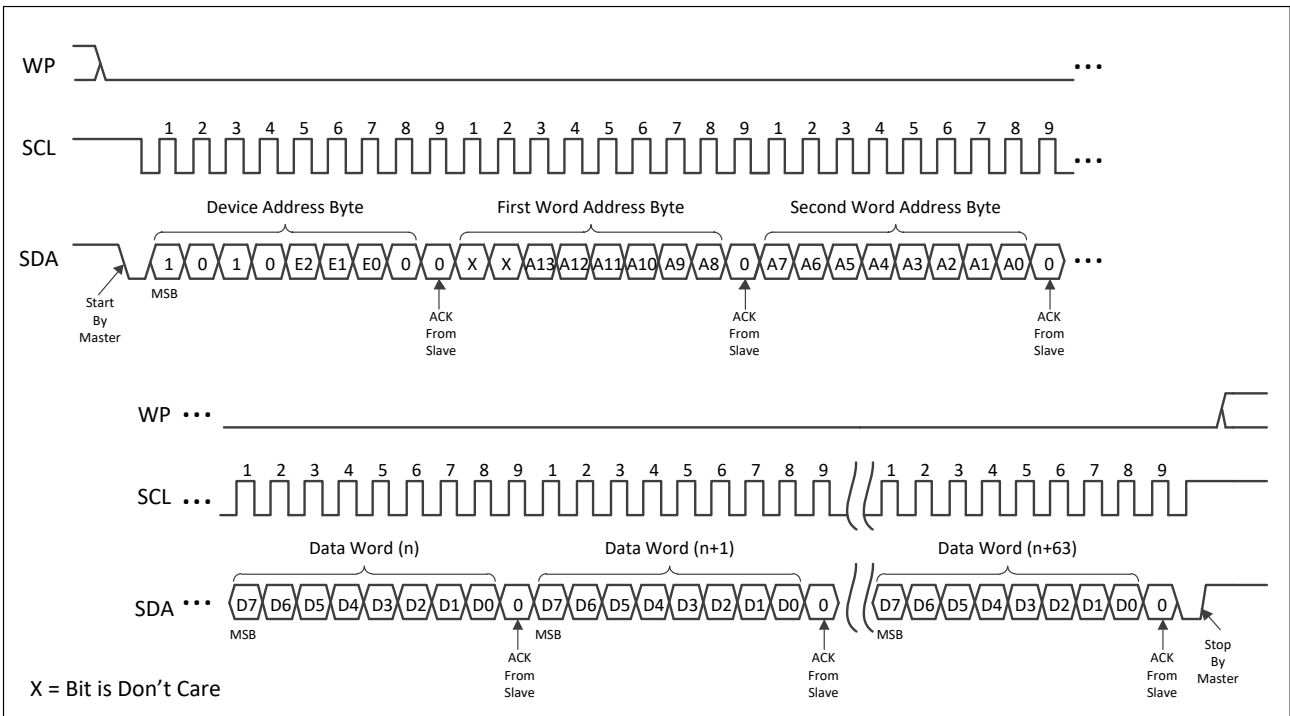
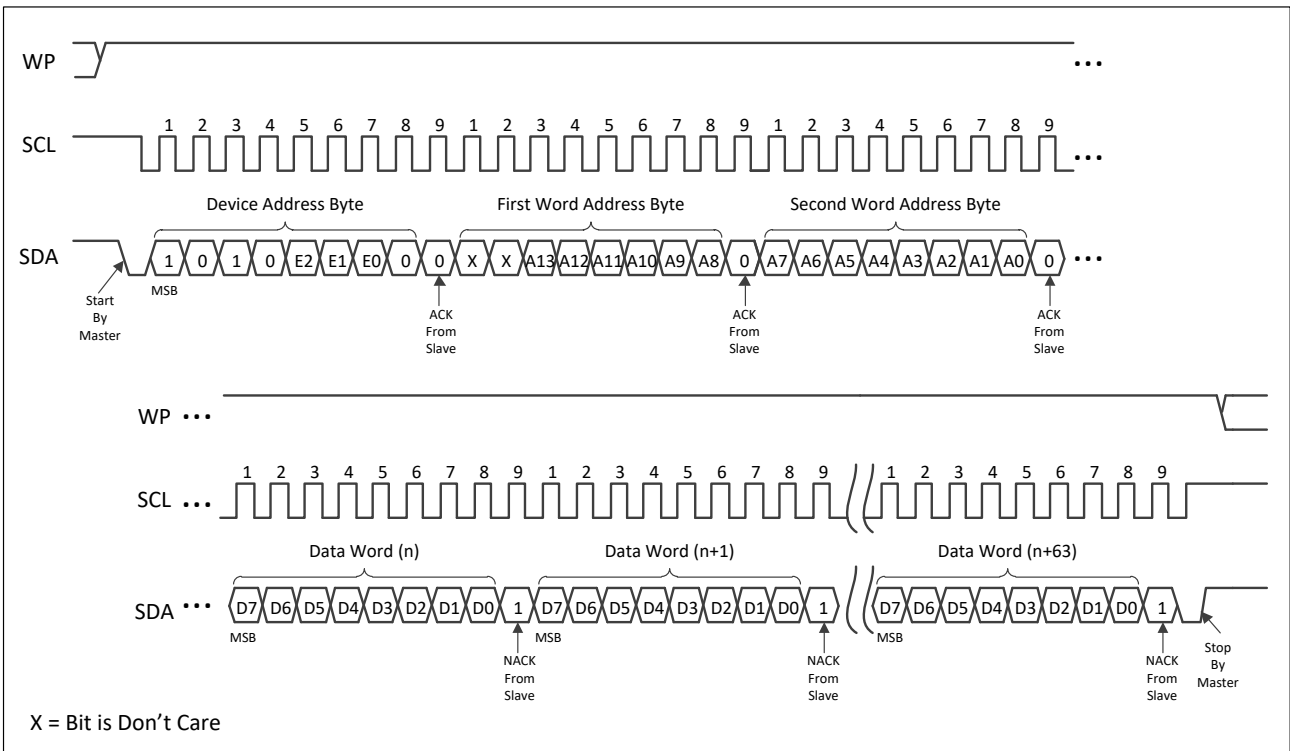

Figure 5–4 Page Write Operation with Write Protection Pin Set to High



5.1.3 Write Cycle Timing

The length of the self-timed write cycle, or t_{WR} , is defined as the amount of time from a valid Stop condition that begins the internal write sequence to the Start condition of the first device address byte sent to the WB24C128 that it subsequently responds to with an ACK (see [Figure 5–5](#)).

Figure 5-5 Write Cycle Timing

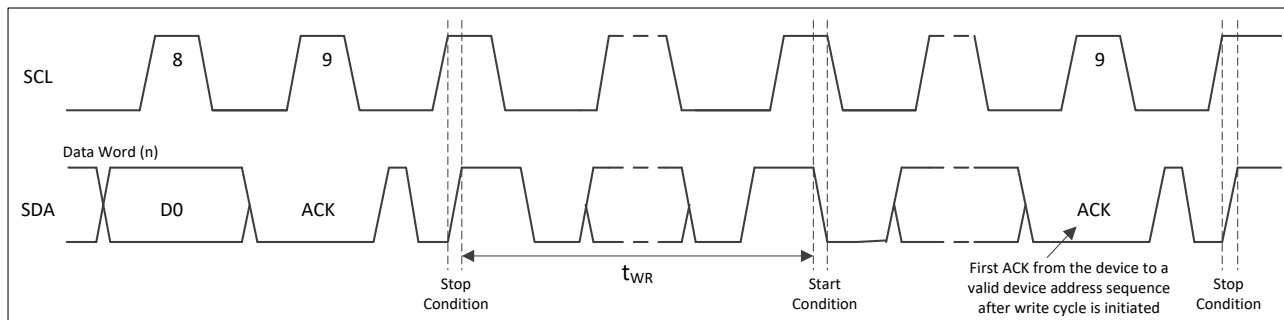

5.1.4 Acknowledge (ACK) Polling

An ACK polling routine can be implemented to optimize time sensitive applications that would not prefer to wait the fixed maximum write cycle time but would prefer to know immediately when the Serial EEPROM write cycle has completed to start a subsequent operation. Once the internally self-timed write cycle has started, the device inputs are disabled and ACK polling can be initiated. An ACK polling routine involves sending a valid Start condition followed by the device address byte. While the write cycle is in progress, the device will not respond with an ACK, indicating the device is busy writing data. Once completed, the device returns an ACK and the next device operation can be started (see [Figure 5-6](#)).

Figure 5-6 Acknowledge Polling Flow Chart

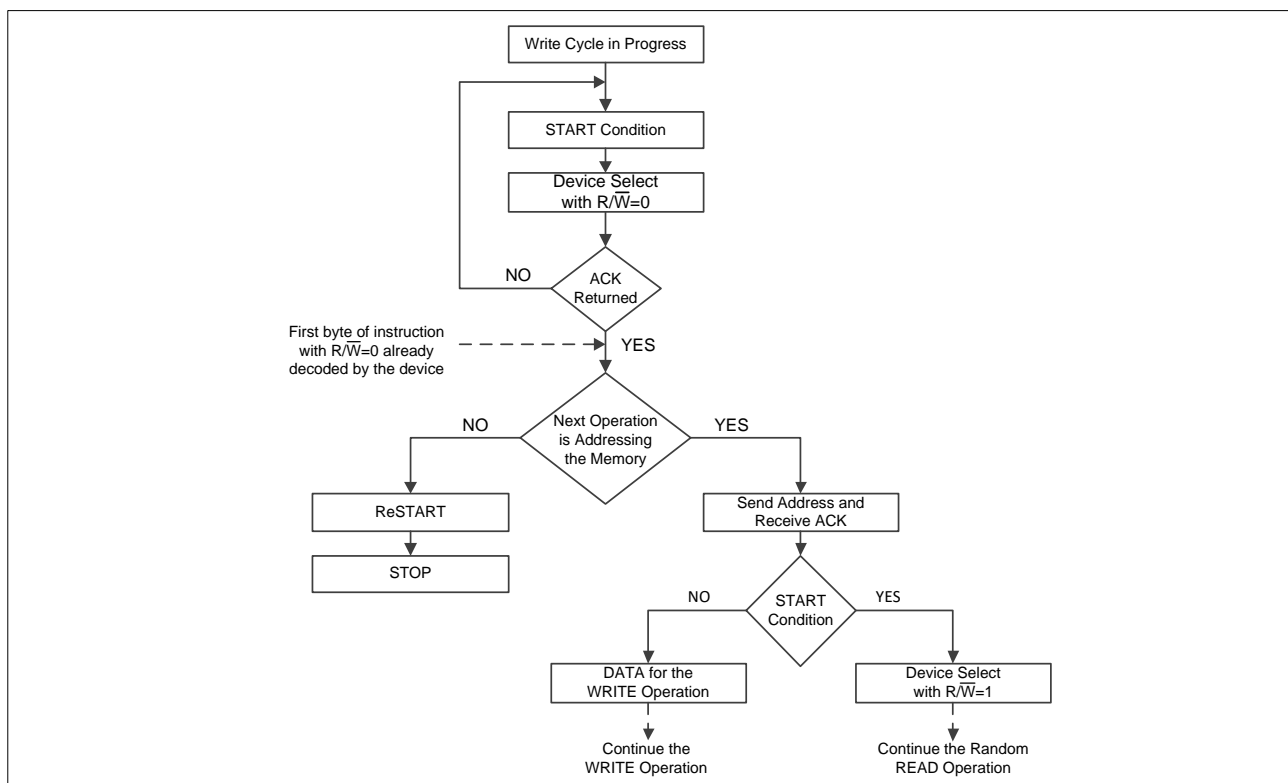

5.1.5 Write Identification Page

The WB24C128 offers a 64-byte Identification Page (ID Page) in addition to the 128-Kbit memory array for storage of specific application data. This Identification Page can be written and permanently locked in Read-only mode after the data is written into this Page. The Identification Page is written by issuing the Write Identification Page instruction (see [Figure 5-7](#)), which is similar to Page Write, except that:

- The device type identifier is defined as '1011';
- The word address bits A10:A9 must be '00', bits A15:A11 and A8:A6 are Don't Care;
- The word address bits A5:A0 define the byte locations inside the ID Page (see [Table 4-2](#)).

If the Identification Page has been locked, the data bytes transferred during the Write Identification Page instruction will not be acknowledged.

Figure 5-7 Write Identification Page

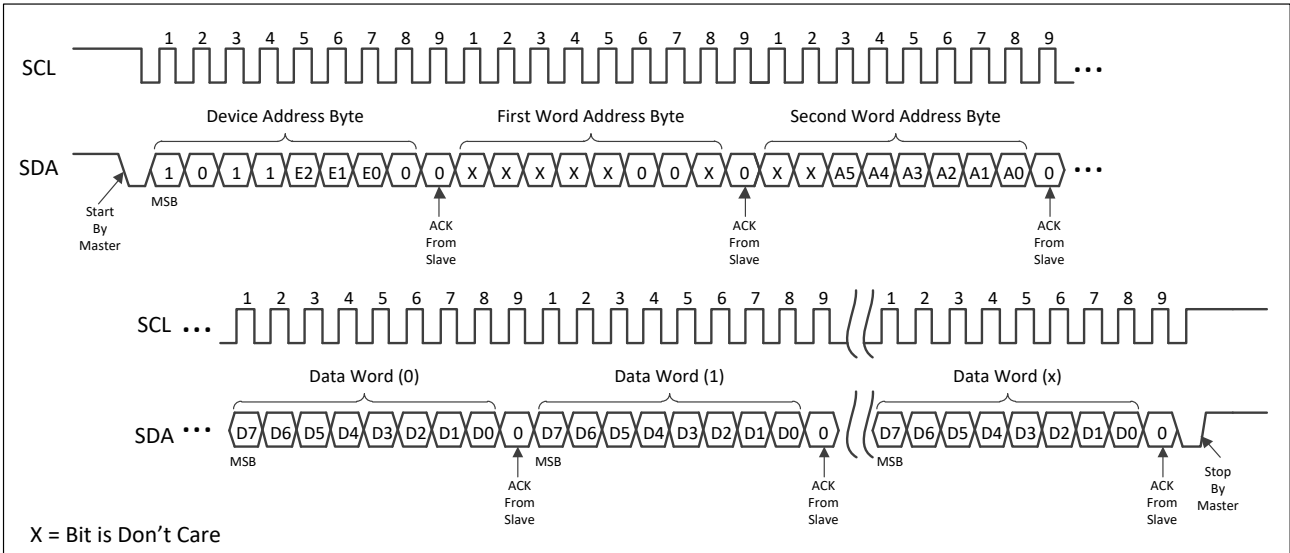

5.1.6 Lock Identification Page

The Lock Identification Page (Lock ID) instruction permanently locks the Identification Page in Read-only mode. The Lock ID instruction is similar to Byte Write, except the following specific conditions:

- The device type identifier is defined as '1011';
- The word address bits A10:A9 must be '10' and other word address bits are Don't Care;
- The data byte must be equal to the binary value xxxx_xx1x, where x is Don't Care (see [Figure 5-8](#)).

Once a valid Lock ID instruction has been executed, if another Lock ID instruction is issued, the device will respond with a NACK to the data byte.

Figure 5-8 Lock Identification Page

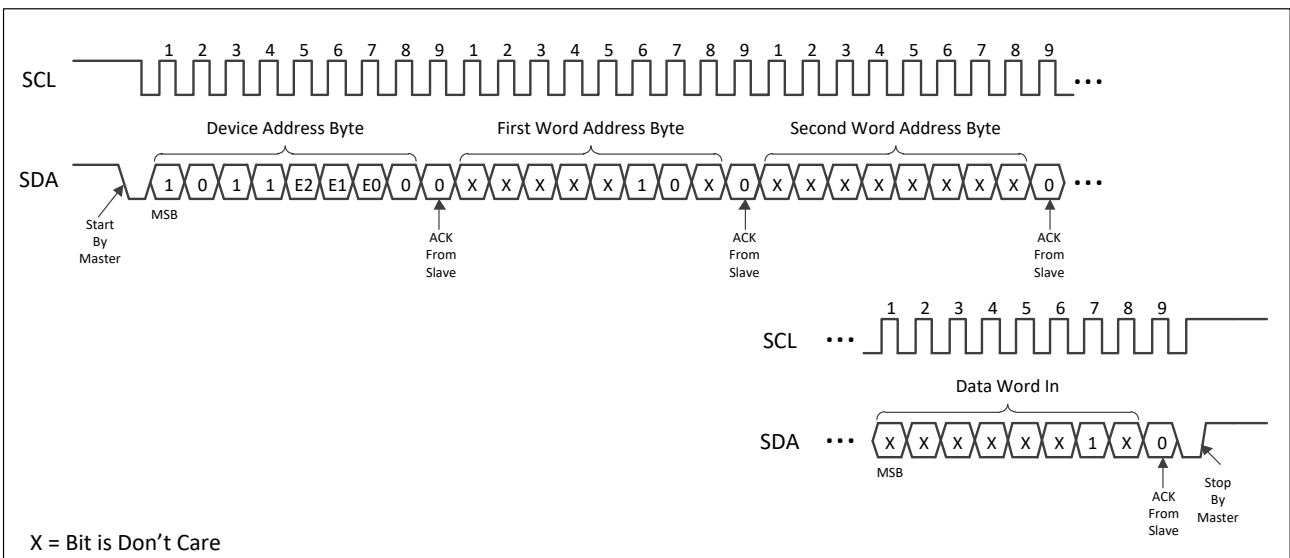

5.2 Read Operations

All Read operations are initiated by the Master transmitting a Start condition, a device type identifier of '1010' or '1011', three software device address bits (E2, E1, E0) that match corresponding hard-wired address pins (E2, E1, E0), and the $\overline{R/W}$ select bit with Logic 1 state. In the following clock cycle, the WB24C128 should respond with an ACK. The subsequent protocol depends on the type of Read operation desired. There are three Read operations for memory array: Current Address Read, Random Address Read, and Sequential Read with the device type identifier of '1010'; three Read operations for Identification Page and Unique ID: Read Identification Page, Read the Lock Status, and Read Unique ID with the device type identifier of '1011'. Read operations are performed independently of the state of the WP pin connection.

5.2.1 Current Address Read

For a Current Address Read operation, the Master sends a Start condition followed by transmitting the device address byte with the $\overline{R/W}$ bit set to Logic 1 (see [Figure 5-9](#)). The WB24C128 should respond with an ACK and then serially transmits the data word addressed by the internal address counter. This address maintained by the internal address counter is the last address accessed during the last Read or Write operation. The counter is then incremented by one and the address will stay valid between operations as long as power to the device is supplied. The address roll-over during a Read operation is from the last byte of the last page to the first byte of the first page. To end the command, the Master responds with a NACK followed by a Stop condition.

Note that the internal address counter value is defined by instructions accessing the 128-Kbit memory or the Identification Page or the Unique ID. For example, when accessing the ID Page, the counter value is loaded with the byte location in the ID Page. Therefore the next Current Address Read in the memory uses this new address counter value. When accessing the memory, it is recommended to always use the Random Read instruction (see [Section 5.2.2](#)) instead of the Current Address Read instruction.

Figure 5-9 Current Address Read

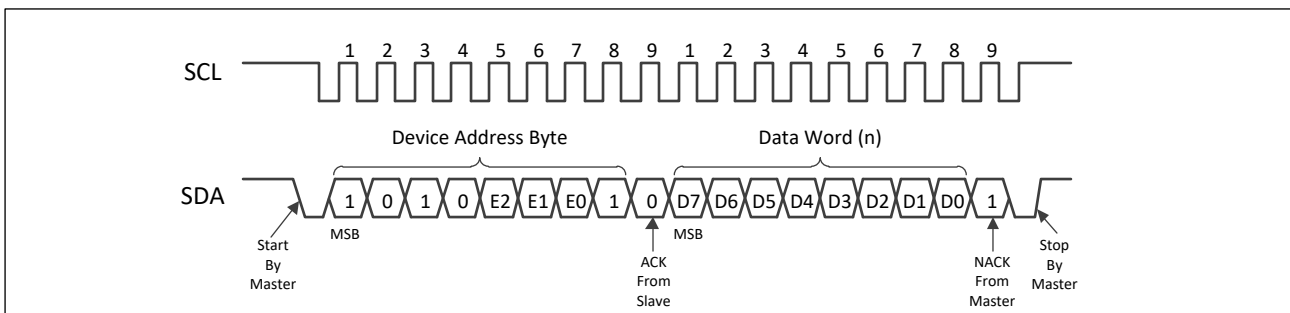

5.2.2 Random Read

A Random Read operation allows the Master to access any memory location in a random manner and requires a dummy write sequence to preload the starting data word address. To perform a Random Read, the device address byte and the word address bytes are transmitted to the WB24C128 as part of the dummy write sequence (see [Figure 5-10](#)). Once the device address byte and word address bytes are clocked in and acknowledged by the WB24C128, the Master must generate another Start condition. The Master initiates a Current Address Read by sending another device address byte with the $\overline{R/W}$ bit set to Logic 1. The WB24C128 responds with an ACK to the device address byte and serially clocks out the first

data word and increments its internal address counter. The device will continue to transmit sequential data words as long as the Master continues to acknowledge each data word. To end the sequence, the Master responds with a NACK followed by a Stop condition.

Figure 5-10 Random Read

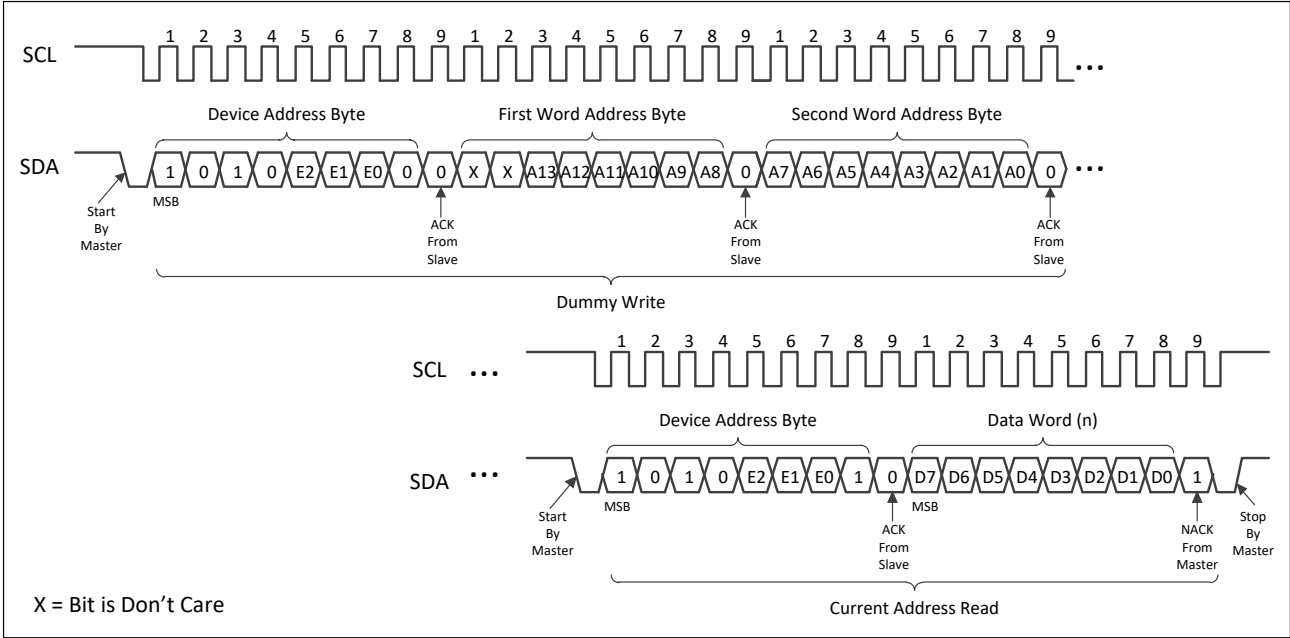

5.2.3 Sequential Read

A Sequential Read operation is initiated in the same way as either a Current Address Read or a Random Read, except that after the WB24C128 transmitting the first data word, the Master responds with an ACK instead of a NACK. As long as the WB24C128 receives an ACK, it will continue to increment the data word address and serially clock out the sequential data words (see Figure 5-11). When the internal address counter is at the last byte of the last page, the word address will roll over to the beginning of the memory array and the Sequential Read operation will continue. The Sequential Read operation is terminated by the Master responding with a NACK followed by a Stop condition.

Figure 5-11 Sequential Read

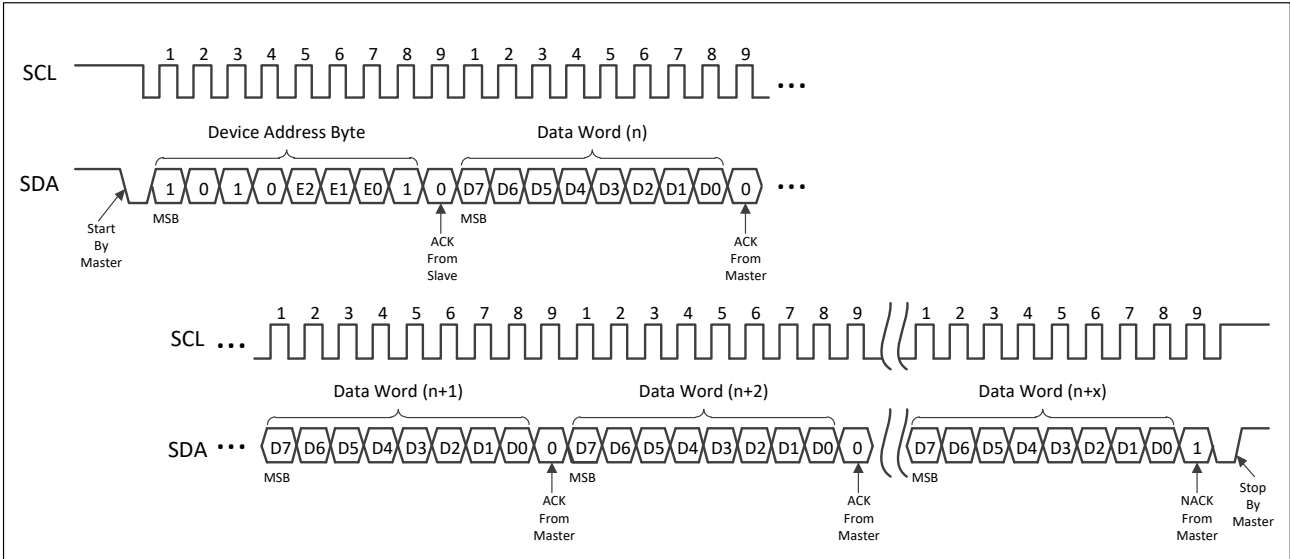

5.2.4 Read Identification Page

The Identification Page can be read by issuing a Read Identification Page instruction. This instruction uses the same protocol and format as Random Read, except that:

- The device type identifier is defined as '1011';
- The word address bits A10:A9 must be '00', bits A15:A11 and A8:A6 are Don't Care;
- The word address bits A5:A0 define the byte locations inside the ID Page (see [Table 4-2](#)).

When the end of Identification Page is reached, the word address will roll over to the beginning of the Identification Page. The Read Identification Page operation is terminated by the Master responding with a NACK followed by a Stop condition (see [Figure 5-12](#)).

Figure 5-12 Read Identification Page

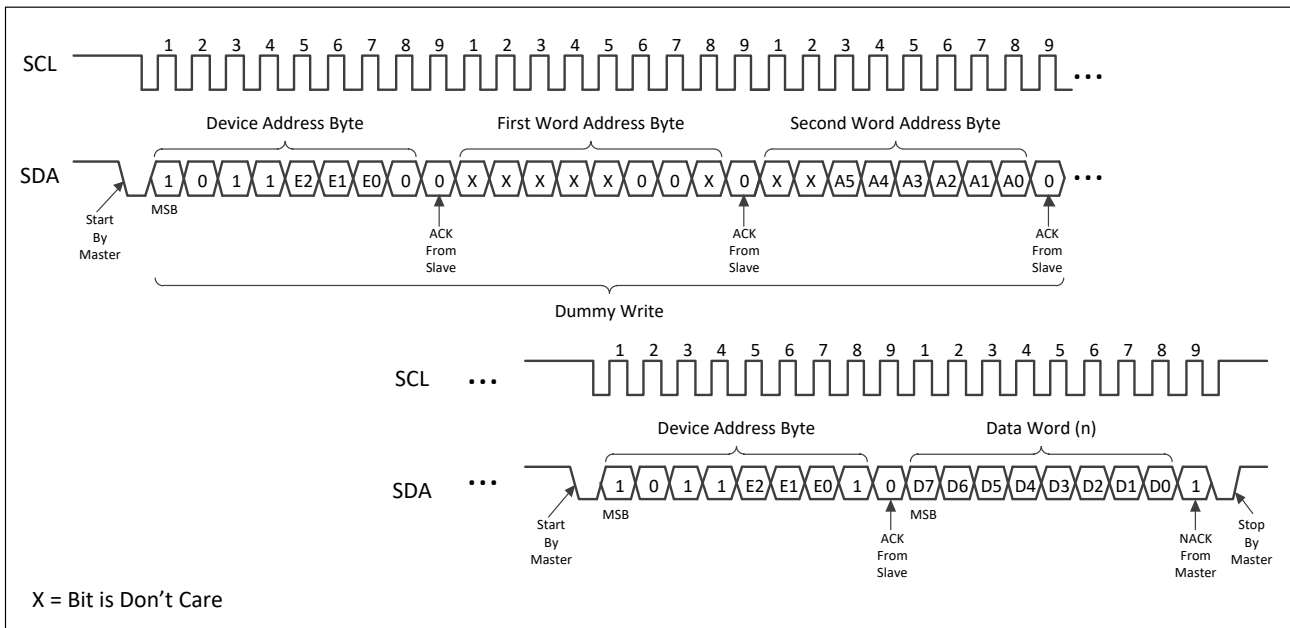

5.2.5 Read Lock Status

The locked/unlocked status of the Identification Page can be checked by transmitting a specific truncated command, Write Identification Page instruction and one data byte to the device. The device responds with an ACK to the data byte if the Identification Page is unlocked, or responds with a NACK if the Identification Page has been locked. Right after this, it is recommended to transmit a Start condition to the device followed by a Stop condition (see [Figure 5-13](#)), so that the truncated Write command will not be executed because the Start condition resets the device internal logic, and the device is then set back into Standby mode by the Stop condition.

5.2.6 Read Unique ID

The WB24C128 offers a separate memory block containing a factory programmed 128-bit Unique ID (UID), or Serial Number. Reading the Serial Number is similar to Sequential Read, except that:

- The device type identifier is defined as '1011';
- The word address bits A10:A9 must be '01', bits A15:A11 and A8:A4 are Don't Care;
- The word address bits A3:A0 define the byte locations inside the Unique ID (see [Table 4-2](#)).

In order to guarantee a unique number, the entire 128-bit value must be read from the starting address of the Serial Number block. Reading from a location other than the first address of the block will not result in

a unique Serial Number. To read the first byte of the Serial Number, the word address bits A3:A0 need to be '0000'. Writing or altering the 128-bit Unique ID is not allowed. When the end of the 128-bit UID block is reached (16 bytes of data), the word address will roll over to the beginning of the 128-bit UID block. The Read Unique ID operation is terminated when the Master responds with a NACK to the data byte followed by a Stop condition (see [Figure 5-14](#)).

Figure 5-13 Read Lock Status

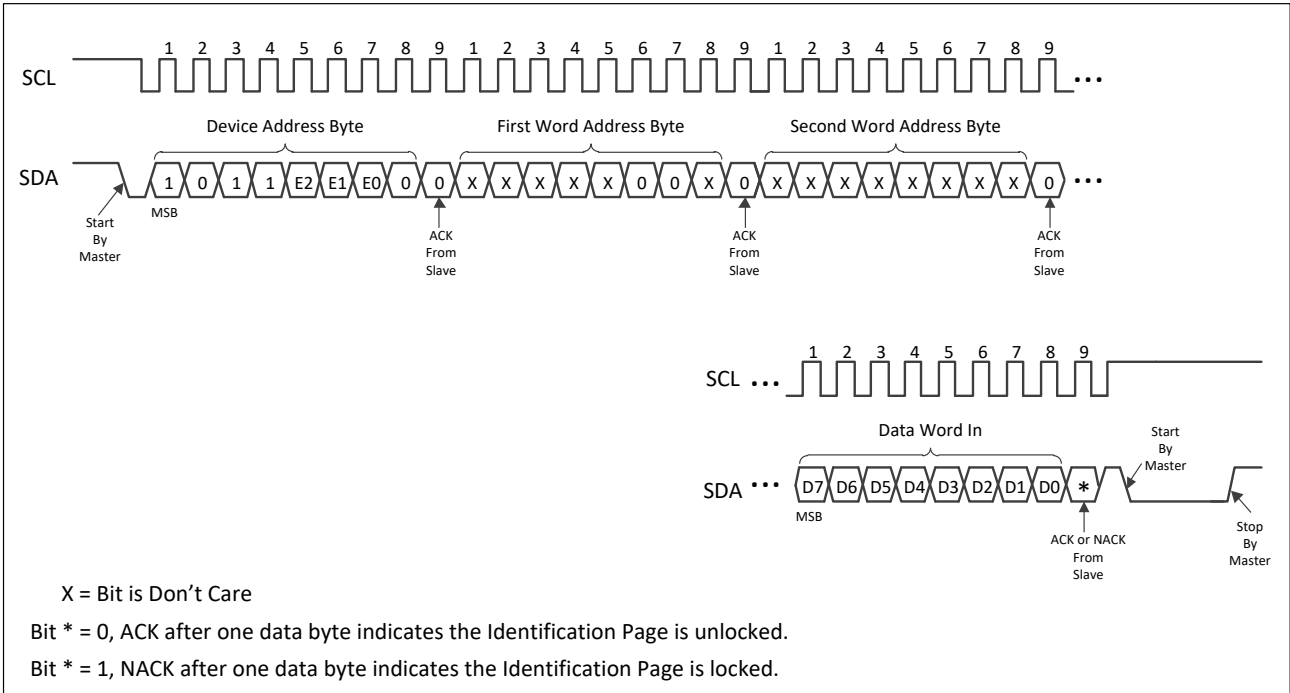
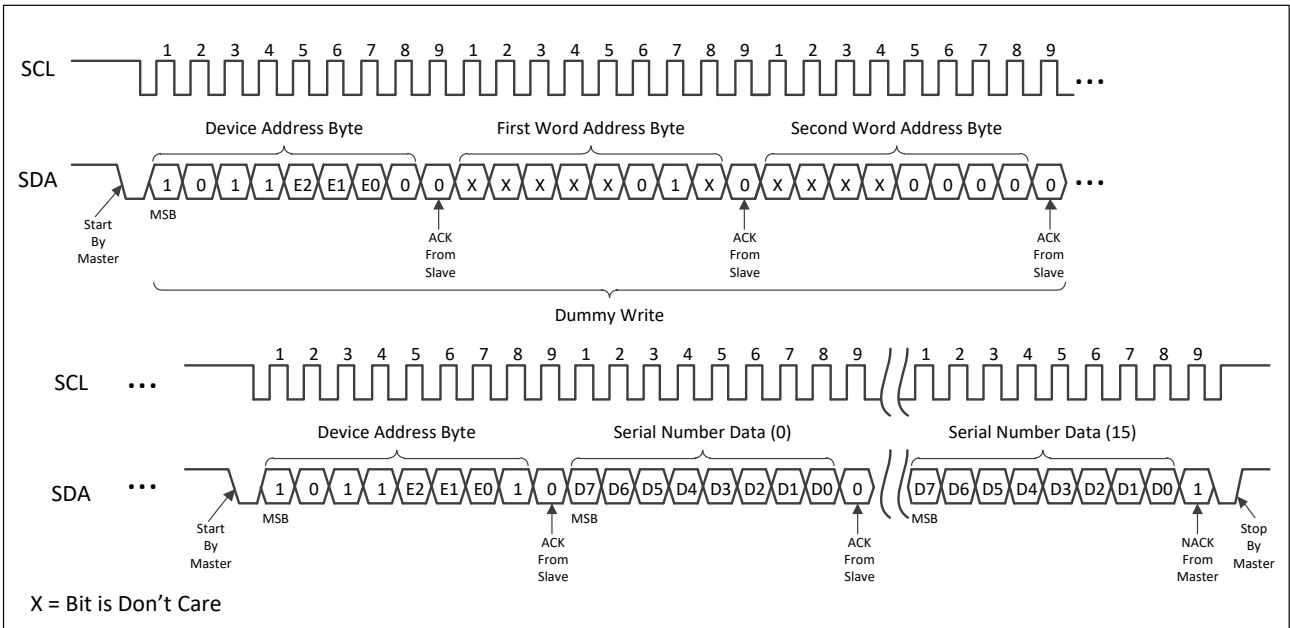

Figure 5-14 Read Unique ID



6 Electrical Specifications

6.1 Absolute Maximum Ratings

Table 6–1 Absolute Maximum Ratings

Symbol	Parameter	Value	Unit
T_A	Ambient temperature with power applied	-40 to +105	°C
T_{STG}	Storage temperature	-65 to +150	°C
V_{CC}	Supply voltage	-0.5 to +6.0	V
V_{IN}	Voltage on input Pins	-0.5 to +6.0	V
V_{ESD}	Electrostatic pulse (human body model)	6000	V

Note: Stresses beyond those listed under ‘Absolute Maximum Ratings’ may cause permanent damage to the device. Functional operation of the device at these ratings or any other conditions beyond those indicated in the operational sections of this specification is not implied. Exposure to absolute maximum rating conditions for extended periods may affect device reliability.

6.2 DC Characteristics

Operating range: $T_A = -40^{\circ}\text{C}$ to $+105^{\circ}\text{C}$, $V_{CC} = 1.7\text{V}$ to 5.5V (unless otherwise noted).

Table 6–2 DC Characteristics

Symbol	Parameter	Test Condition	Min	Max	Unit
V_{CC}	Supply Voltage		1.7	5.5	V
I_{CC1}	Supply Current (Read)	$V_{CC} = 1.7\text{V}$, Read at 1MHz	-	0.1	mA
		$V_{CC} = 5.5\text{V}$, Read at 400 kHz	-	0.4	mA
		$V_{CC} = 5.5\text{V}$, Read at 1MHz	-	0.5	mA
I_{CC2}	Supply Current (Write)	$V_{CC} = 1.7\text{V}$, Write at 400 kHz	-	0.4	mA
		$V_{CC} = 5.5\text{V}$, Write at 400 kHz	-	1	mA
I_{SB}	Standby Current	$V_{CC} = 1.7\text{V}$, $V_{IN} = V_{CC}$ or GND	-	0.5	μA
		$V_{CC} = 5.5\text{V}$, $V_{IN} = V_{CC}$ or GND	-	1	μA
I_{LI}	Input Leakage Current	$V_{IN} = V_{CC}$ or GND	-	1	μA
I_{LO}	Output Leakage Current	$V_{OUT} = V_{CC}$ or GND	-	1	μA
V_{IL}	Input Low-Level Voltage (SDA, SCL)		-0.5	$0.3 \cdot V_{CC}$	V
V_{IH}	Input High-Level Voltage (SDA, SCL)		$0.7 \cdot V_{CC}$	$V_{CC} + 0.5$	V
V_{OL1}	Low-Level Output Voltage	$V_{CC} > 2\text{V}$, $I_{OL} = 3\text{mA}$	-	0.4	V
V_{OL2}	Low-Level Output Voltage	$V_{CC} \leq 2\text{V}$, $I_{OL} = 2\text{mA}$	-	0.2	V

6.3 AC Characteristics

Operating range: $T_A = -40^{\circ}\text{C}$ to $+105^{\circ}\text{C}$, $V_{CC} = 1.7\text{V}$ to 5.5V , $C_L = 100\text{pF}$ (unless otherwise noted).

Measurement conditions: Input rise and fall time $\leq 50\text{ns}$

Input pulse voltages: $0.2 \cdot V_{CC}$ to $0.8 \cdot V_{CC}$

Input and output timing reference voltages: $0.3 \cdot V_{CC}$ to $0.7 \cdot V_{CC}$

Table 6–3 AC Characteristics

Symbol	Parameter	Fast $V_{CC} = 1.7V$ to $5.5V$		High Speed $V_{CC} = 1.7V$ to $5.5V$		Unit
		Min	Max	Min	Max	
f_{SCL}	Clock Frequency, SCL	-	400	-	1000	kHz
t_{LOW}	Clock Pulse Width Low	1300	-	600	-	ns
t_{HIGH}	Clock Pulse Width High	600	-	260	-	ns
$t_R^{[1]}$	SDA Rise Time	-	300	-	300	ns
$t_F^{[1]}$	SDA(Out) Fall Time	-	300	-	100	ns
$t_{HD,STA}$	Start Hold Time	600	-	250	-	ns
$t_{SU,STA}$	Start Setup Time	600	-	250	-	ns
$t_{SU,STO}$	Stop Setup Time	600	-	250	-	ns
t_{BUF}	Bus Free Time between Stop and Next Start	1300	-	500	-	ns
$t_{HD,DI}$	Data In Hold Time	0.0	-	0.0	-	ns
$t_{SU,DAT}$	Data In Setup Time	100	-	50	-	ns
$t_{HD,DAT}$	Data Out Hold Time	50	-	50	-	ns
t_{AA}	SCL Low to Data Out Valid	100	900	50	500	ns
$t_{SU,WP}$	WP Pin Setup Time	1200	-	600	-	ns
$t_{HD,WP}$	WP Pin Hold Time	1200	-	600	-	ns
t_{WR}	Write Cycle Time	-	5	-	5	ms
t_i	Noise Suppression Time	-	50	-	50	ns

Notes: ^[1] This parameter is ensured by characterization only.

Figure 6–1 Bus Timing

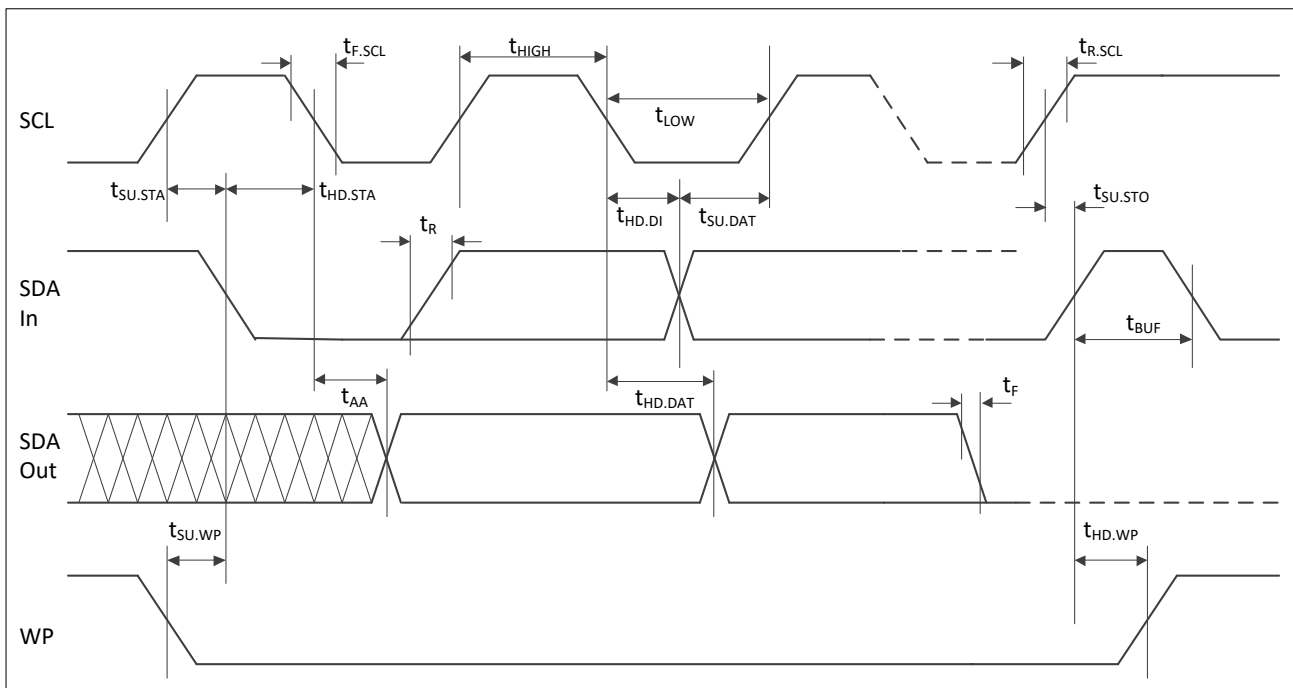
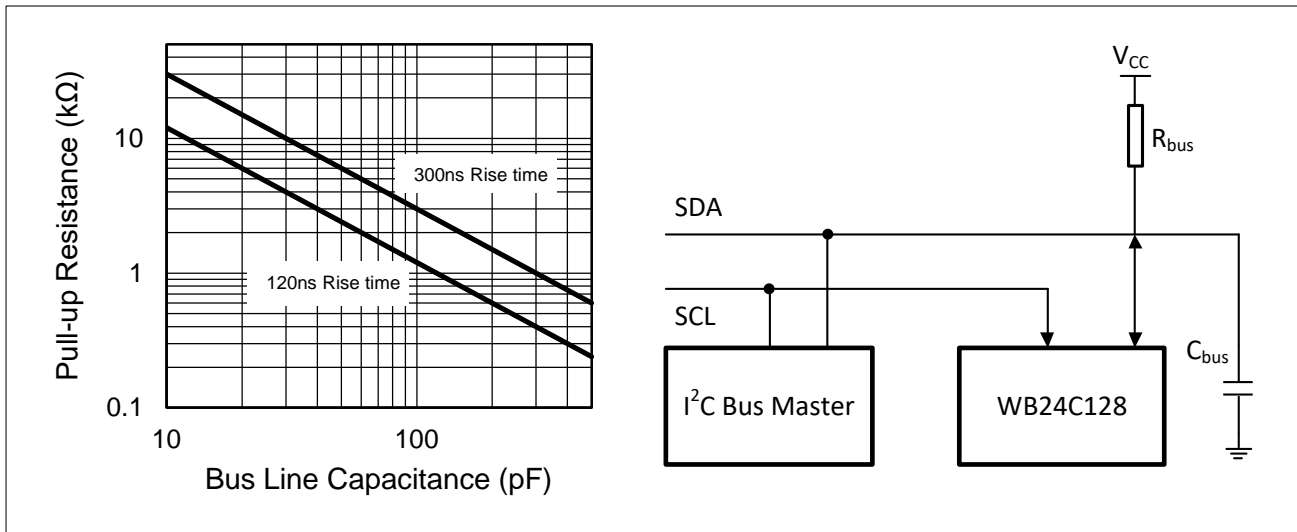

Figure 6–2 Maximum Pull-up Resistance vs. Bus Parasitic Capacitance



6.4 Pin Capacitance

Operating range for pin capacitance: $T_A = +25^\circ\text{C}$, $f_C = 1\text{MHz}$, $V_{CC} = 1.7\text{V}$ to 5.5V .

Table 6–4 Pin Capacitance

Symbol	Parameter ^[1]	Max	Unit	Test Condition
$C_{I/O}$	Input/output Capacitance (SDA)	8	pF	$V_{I/O} = 0\text{V}$
C_{IN}	Input Capacitance (other pins)	6	pF	$V_{IN} = 0\text{V}$

Note: ^[1] These parameters are ensured by characterization only.

6.5 Reliability Characteristics

Table 6–5 Reliability Characteristics

Symbol	Parameter	Min	Unit	Test Condition
N_W	Write Cycle Endurance	2×10^6	cycle	$T_A = +25^\circ\text{C}$, Page Mode
D_R	Data Retention	200	year	$T_A = +25^\circ\text{C}$

7 Initial Delivery State

The WB24C128 Serial EEPROM is delivered as follows:

- All bits in the memory array are set to '1' (each byte contains FFh).
- All bits in the Identification Page are set to '1' (each byte contains FFh).

WB24C128

8 Ordering Information

Table 8-1 Ordering information scheme

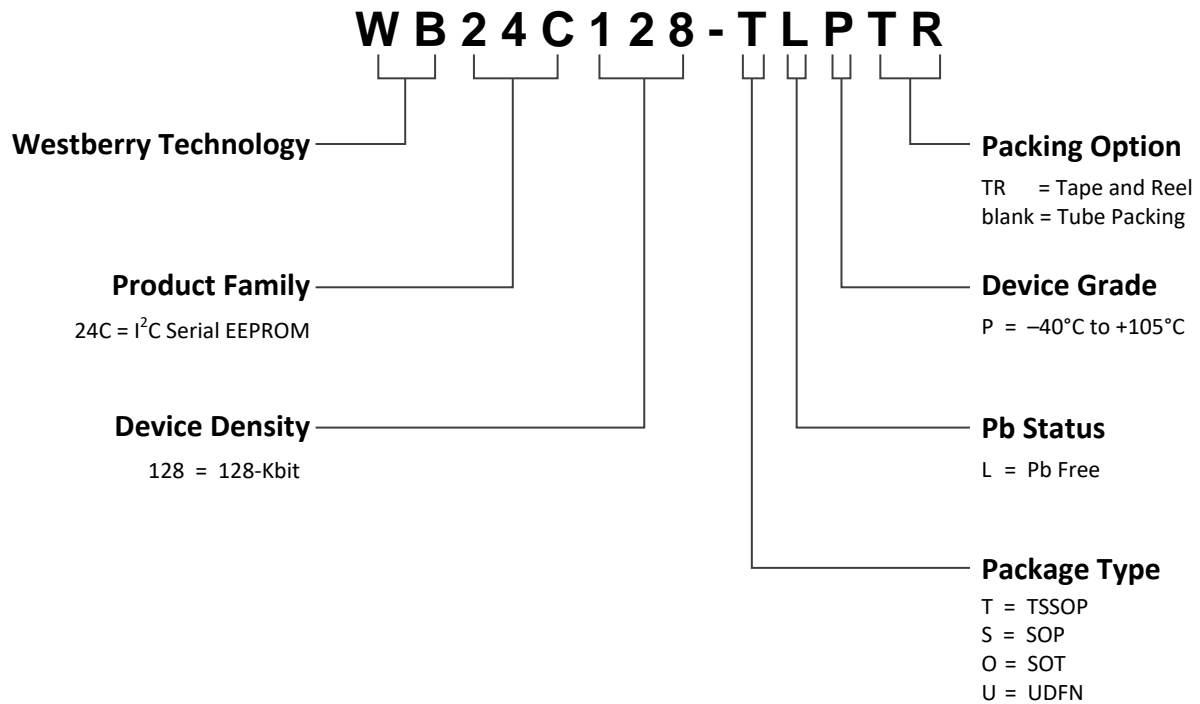

Part Number	Package	Delivery Information	Temperature Range
WB24C128-TLPTR	3.0 x 4.4mm TSSOP	Tape and Reel, 5000 units per Reel	-40°C to +105°C
WB24C128-SLPTR	SOP	Tape and Reel, 4000 units per Reel	-40°C to +105°C
WB24C128-ULPTR	2.0 x 3.0mm UDFN	Tape and Reel, 3000 units per Reel	-40°C to +105°C

9 Package Information

9.1 TSSOP Package Information

Figure 9-1 8-pad 3.0 x 4.4mm TSSOP Package Outline

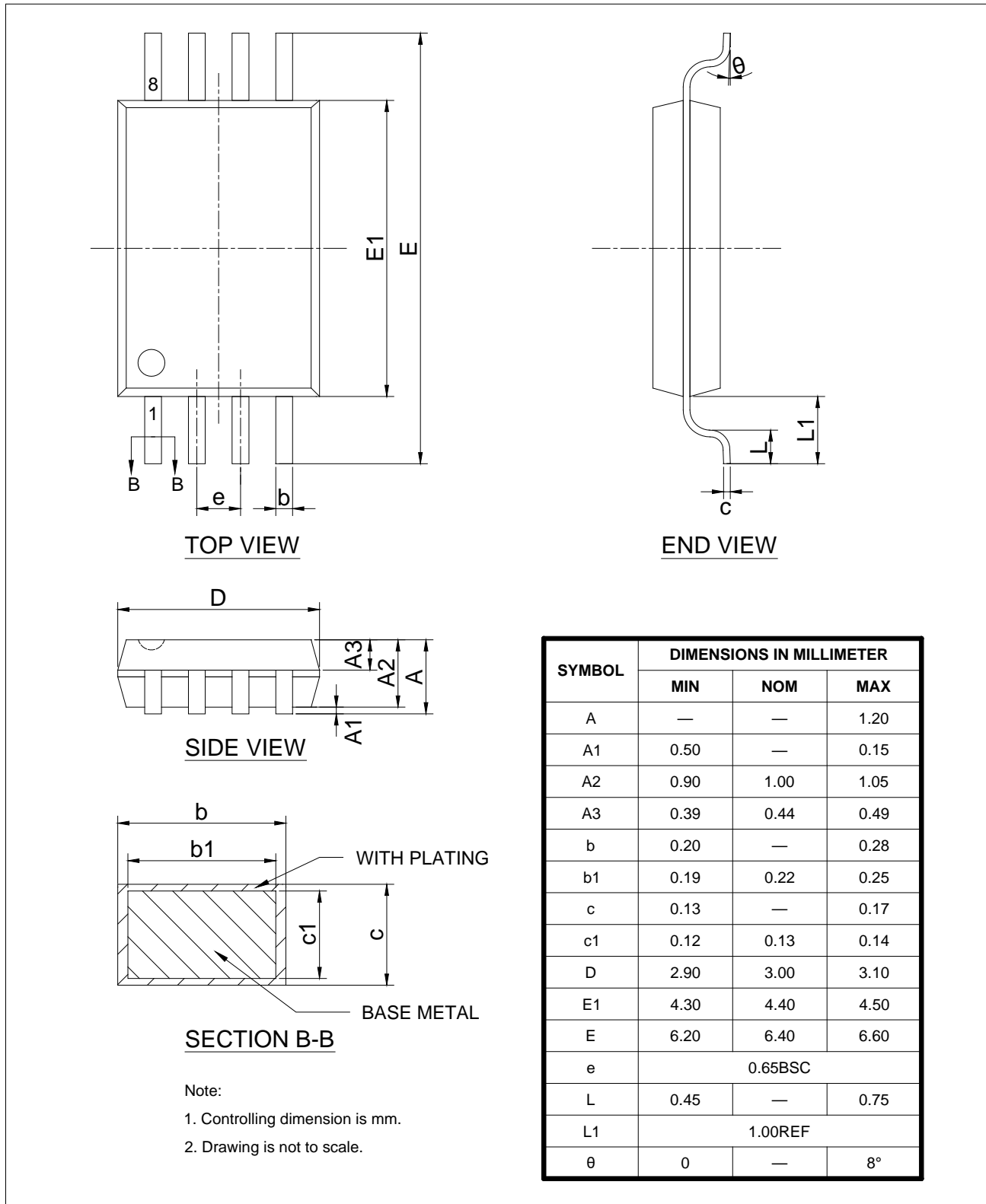

9.2 SOP Package Information

Figure 9-2 8-pad SOP Package Outline

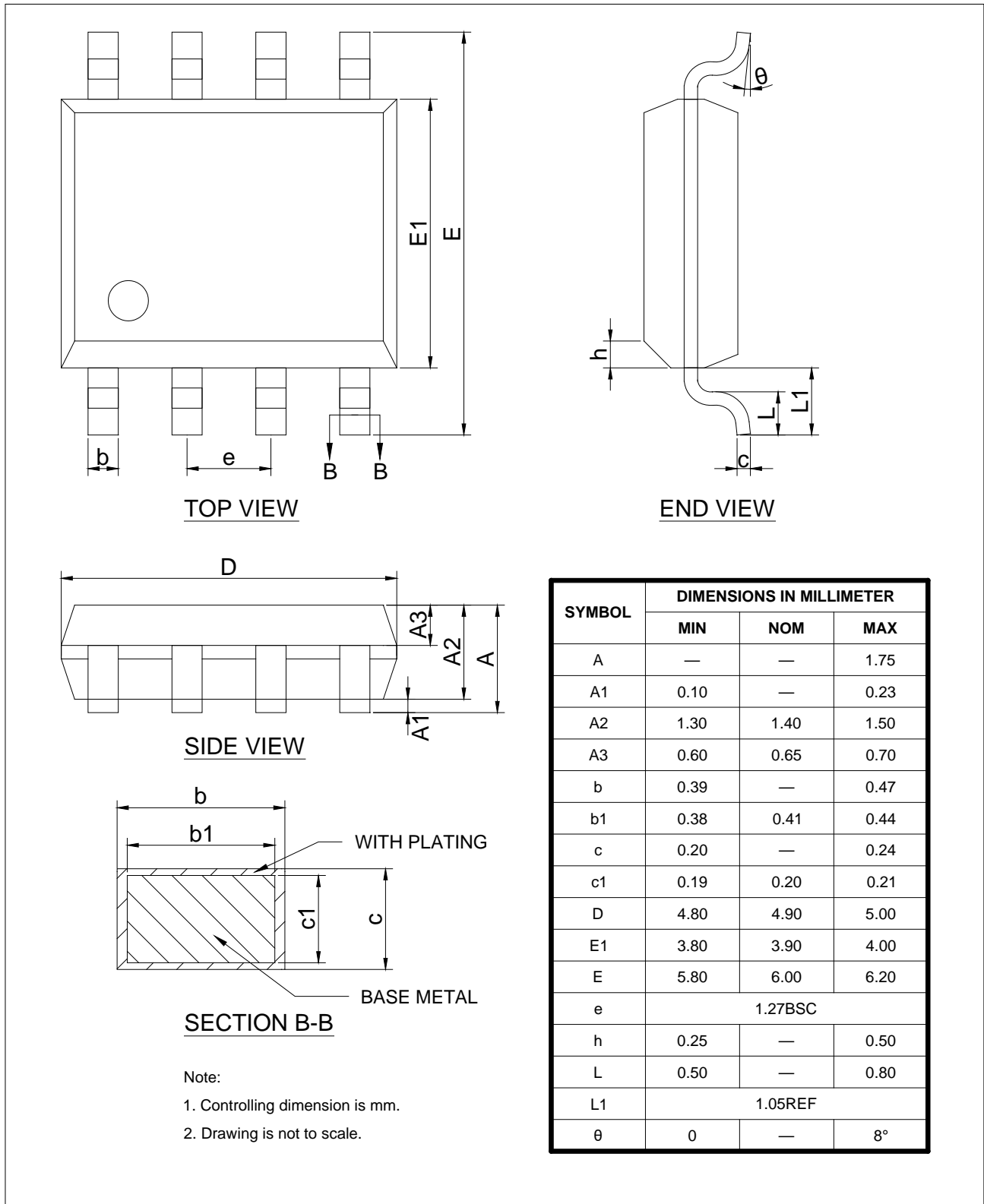

9.3 SOT23-5 Package Information

Figure 9-3 SOT23-5 Package Outline

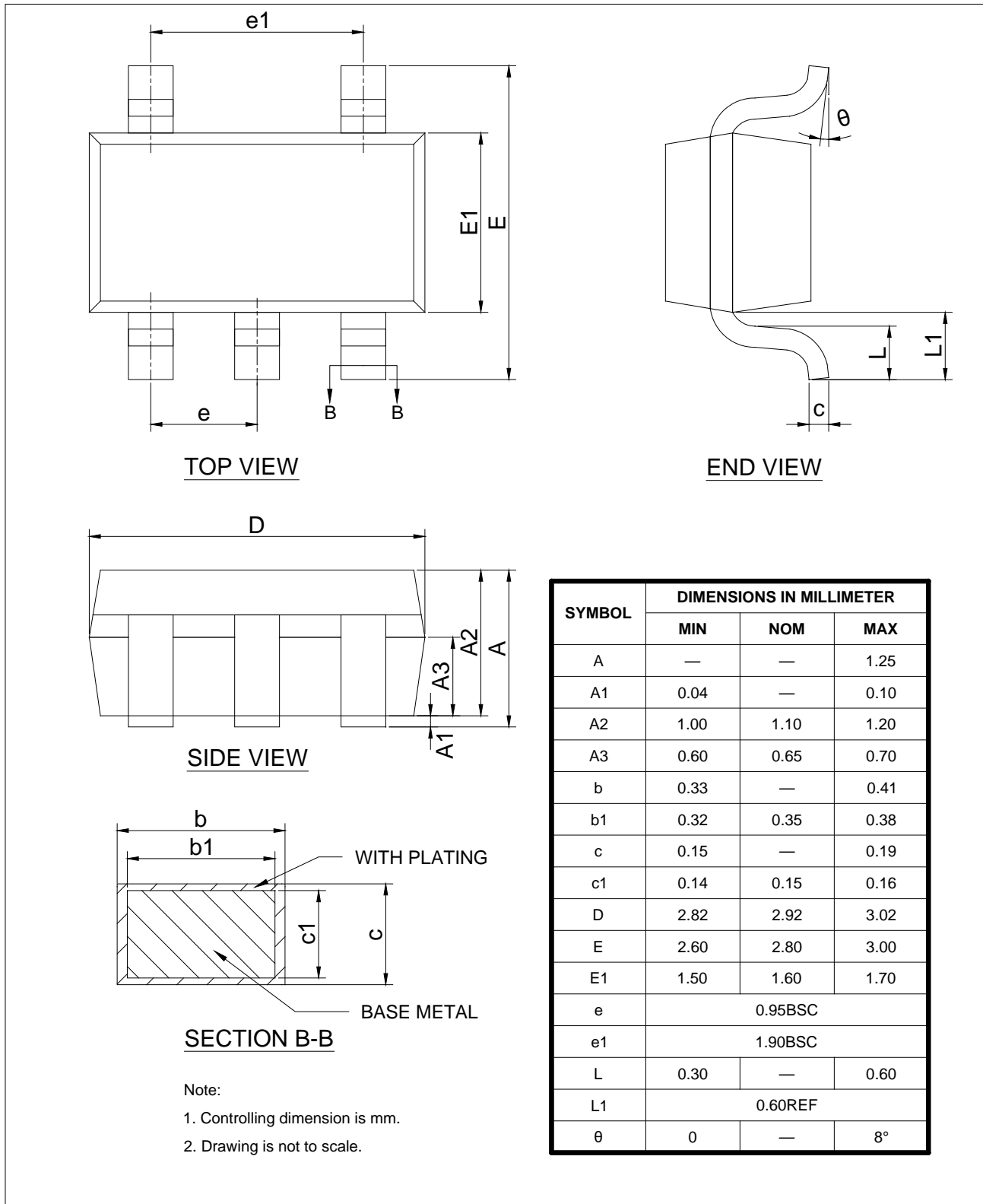

9.4 UDFN Package Information

Figure 9-4 8-lead 2.0 x 3.0mm UDFN Package Outline

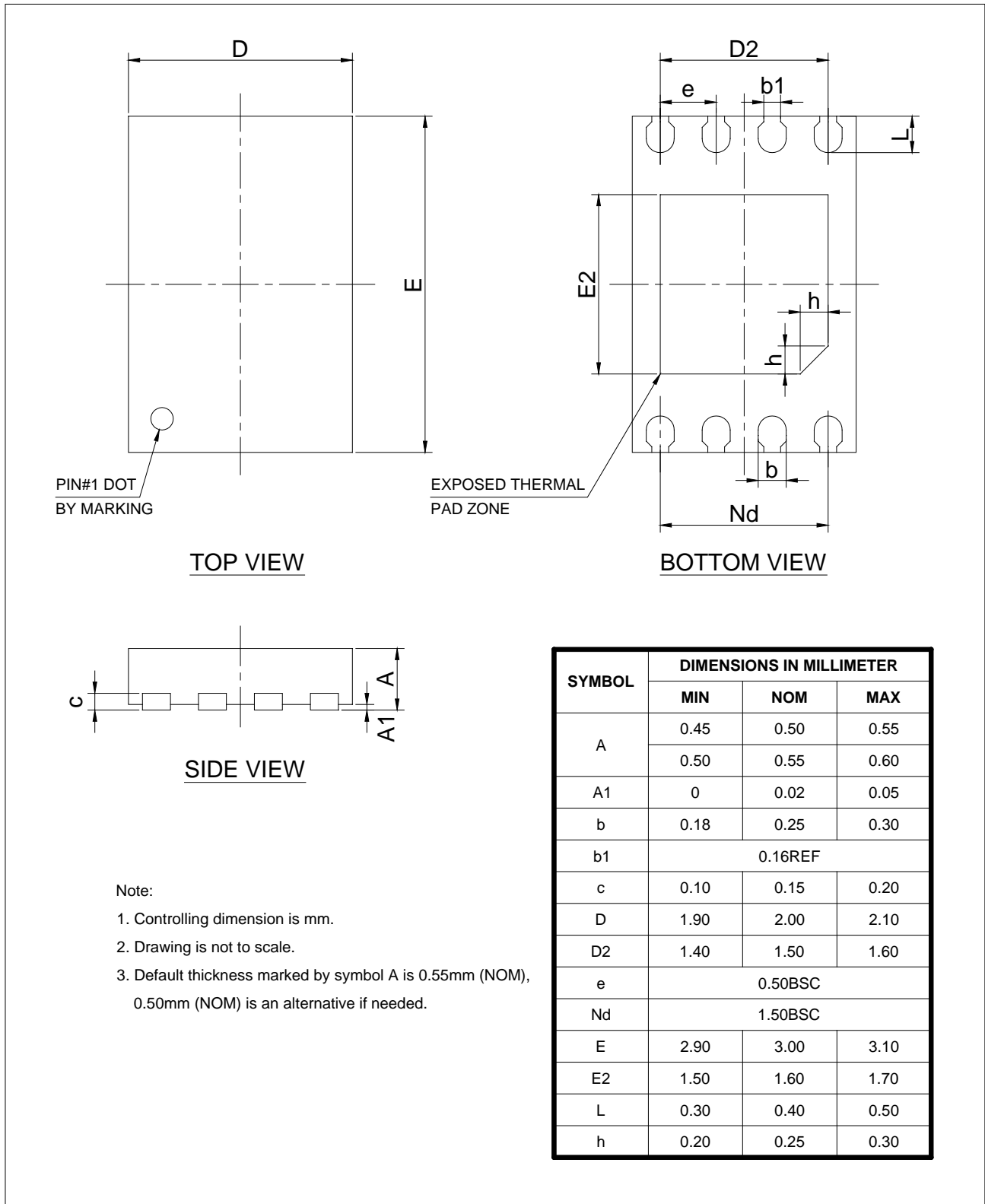

WB24C128

10 Park Marking Scheme

10.1 TSSOP(3.0 x 4.4mm)

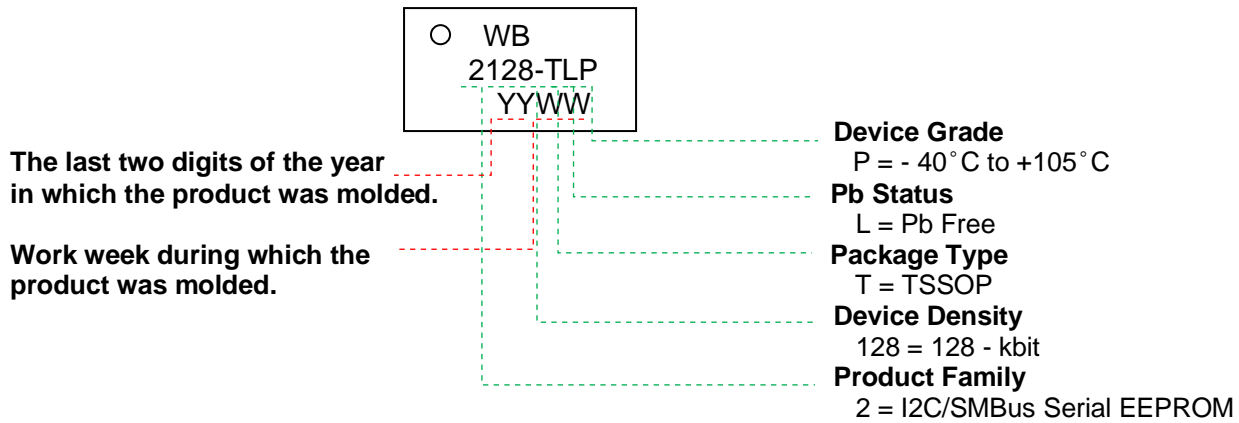

10.2 SOP8

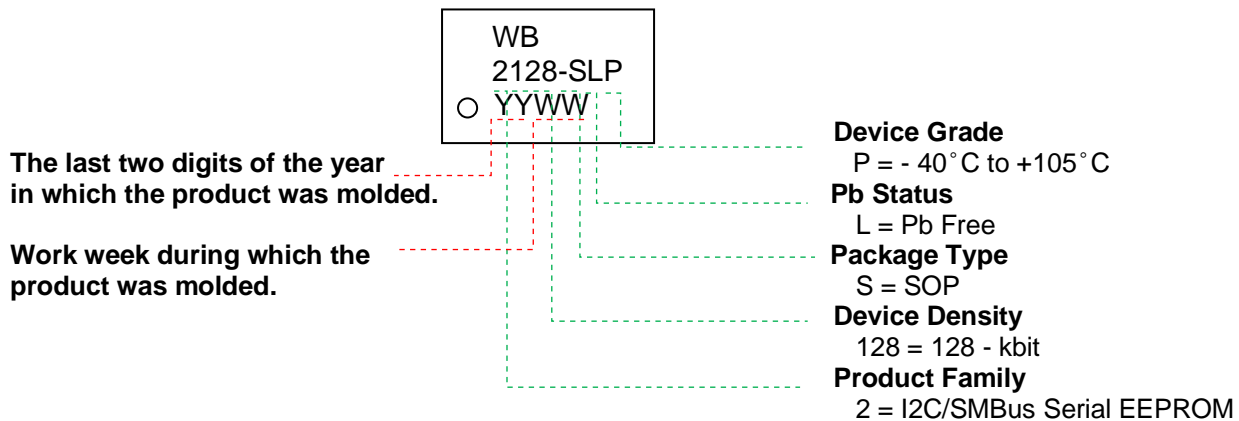

10.3 UDFN(2.0 x 3.0mm)

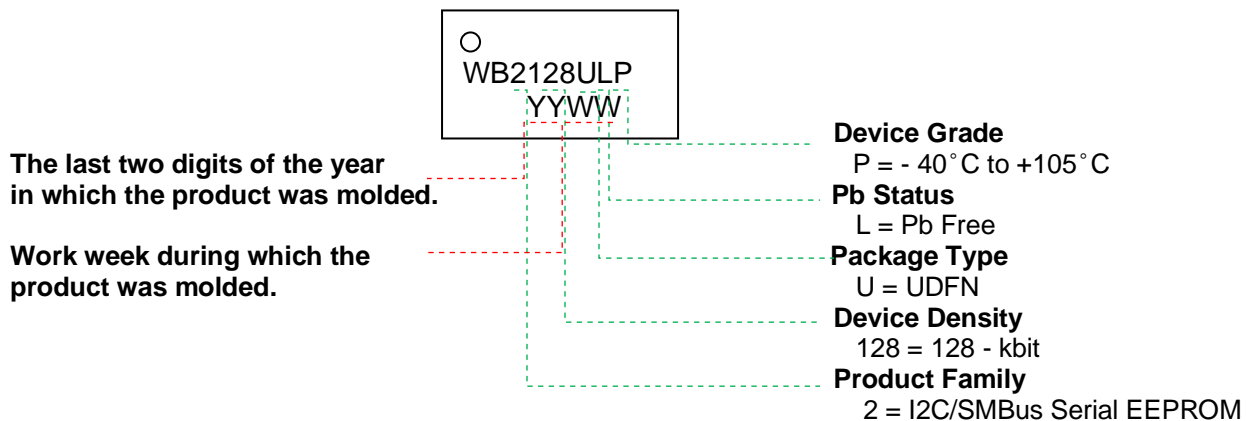

11 Revision History

Revision	Date	Comments
Rev.1.0	Jan. 2020	Initial version release
Rev.1.1	Oct . 2020	Updated Park Marking Scheme
Rev.1.2	Jan. 2021	Updated UDFN Top Mark Scheme
Rev.1.3	Feb. 2021	Add ESD and MSL level feature
Rev.1.4	May. 2021	Updated UDFN MPQ
Rev.1.5	Jul. 2021	Updated TSSOP MPQ